

KL304X-P5

ZERO-CROSS TRIAC DRIVER

PHOTOCOUPLER

DIP5 零交叉双向可控硅驱动光电耦合器

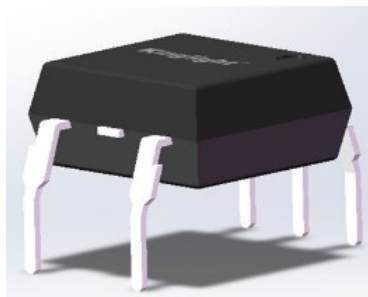
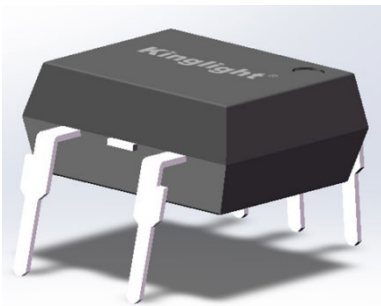

* 本文中包含的信息反映了具有代表性的使用场景，仅供技术参考。

The information contained in this document reflects representative usage scenarios and is intended for technical reference only.

* 本文中提到的产品型号和规格如有更改或改进，恕不另行通知。在生产使用之前，客户应参考产品规格书的最新数据表。

Product models and specifications mentioned in this document are subject to change or improvement without notice. Customers should refer to the latest data sheets in the product specifications prior to production use.

* 在使用本文中引用的产品时，请确保产品在数据手册中规定的环境和电气限制范围内运行。如果客户使用超过指定的限制，晶台将不会对任何后续问题负责。

When using the products referenced in this document, ensure that the products are operated within the environmental and electrical limits specified in the data sheet. If the customer uses the product beyond the specified limits, Kinglight will not be responsible for any subsequent problems.

* 本文档中的信息适用于电子元器件应用中的典型用法。如有任何特殊用途，请向晶台咨询，以获得进一步的帮助。

The information in this document applies to typical use in electronic component applications. For special applications, please contact Kinglight for further assistance.

* 未经晶台允许，不得复制或转载本文件的内容和信息。对于最新的信息，请参考官方网站 [Http://www.kinglight-OC.com](http://www.kinglight-OC.com)。

The contents and information in this document may not be copied or reproduced without the permission of Kinglight. For the latest information, please visit the official website [Http://www.kinglight-OC.com](http://www.kinglight-OC.com).

1. 产品特点 Product features

- 峰值击穿电压 400V Peak breakdown voltage 400V
- 输入与输出间高隔离电压(Viso=5000 V rms)
High isolation voltage between inputs and output (Viso=5000 V rms)
- 零电压交叉 Zero voltage crossing
- 符合欧盟REACH法规 Compliance with EU REACH
- 无Pb且符合ROHS标准 Pb free and RoHS compliant
- 安全审批 Safety approval
CQC认证已批准(编号:CQC23001407999) CQC approved(No. CQC23001407999)
UL认证已批准(编号:UL-CA-2340753-0) UL approved(No. UL-CA-2340753-0)

2. 产品描述 Product Description

- KL304X-P5系列由一个砷化镓红外发光二极管和一个单晶硅芯片的零交叉光电双向晶闸管组成可控硅光电耦合器
The KL304X-P5 of devices each consist of a GaAs infrared emitting diode optically coupled to a monolithic silicon zero voltage crossing photo triac.
- 它被设计用于与逻辑系统到110-380伏线路的设计接口, 如固态继电器、工业控制、电机、螺线管和消费电器
It is designed for use with a discrete power triac in the interface of logic systems to equipment powered from 110 to 380 VAC lines, such as solid-state relays, industrial controls, motors, solenoids and consumer appliances.

3. 产品应用 Product Applications

- 灯光控制、电磁阀控制 Light controls, Solenoid/valve controls
- 静态电源开关、电磁接触器 Static power switch, E.M. contactors
- 交流电机驱动器、交流电动机启动器 AC motor drivers, AC Motor starters
- 温度控制 Temperature controls

4. 功能图 Functional Diagram

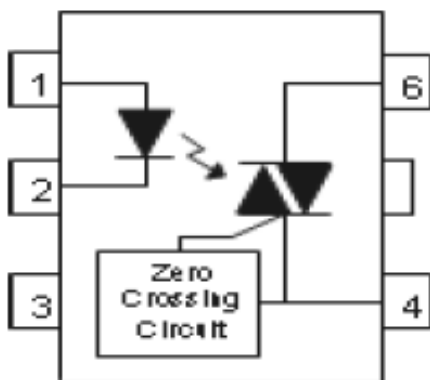

引脚配置 Pin Configuration

1. 阳极 Anode
2. 阴极 Cathode
3. 无连线 No Connection
4. 终端 Terminal
5. 引脚切除 Pin Cut
6. 终端 Terminal

5. 光电特性 Electrical-Optical characteristics

• 最大限度额定值(温度=25°C) Absolute Maximum Ratings(Ta=25°C)

参数 Parameter		符号 Symbol	额定值 Rated Value	单位 Unit
输入 Input	正向电流 Forward current	I_F	60	mA
	反向电压 Reverse voltage	V_R	6	V
	功耗 Power dissipation	P_D	100	mW
	降额系数(高于Ta=85°C) Derating factor (above Ta = 85°C)		3.8	mW /°C
输出 Output	断态输出端电压 Off-state Output Terminal Voltage	V_{DRM}	400	V
	峰值重复浪涌电流 Peak Repetitive Surge Current (pw=1ms,120pps)	I_{TSM}	1	A
	导通有效值电流 On-State RMS Current	$I_{T(RMS)}$	100	mA
	输出功耗 Output Power dissipation	P_C	300	mW
	降额系数 (高于Ta=85°C) Derating factor (above Ta = 85°C)		7.6	mW/°C
总消耗功率 Total Consume Power		P_{TOT}	330	mW
隔离电压 (1*) Isolation Voltage		V_{ISO}	5000	Vrms
工作温度 Operating temperature		T_{OPR}	-55 to +100	°C
储存温度 Storage temperature		T_{STG}	-55 to +125	°C
焊接温度 (2*) Soldering temperature		T_{SOL}	260	°C

附注 (Notes):

1* 交流电源1分钟内, 相对湿度在40~60%RH环境下, 隔离电压测试时, 1&2&3脚短接在一起, 4&6脚短接在一起
AC for 1 minute, R.H.= 40 ~ 60% R.H. In this test, pins 1, 2&3 are shorted together, and pins 4& 6 are shorted together.

2* 焊接时间为10秒 Soldering time is 10 seconds

6. 电气特性(Ta=25°C,除非另有规定)

Electrical Characteristics(Ta=25°C unless specified otherwise)

参数 Parameter		符号 Symbol	最小值 Min.	规格值 Typ.	最大值 Max.	单位 Unit	条件 Condition
输入 In put	正向电压 Forward voltage	V_F	-	-	1.5	V	$I_F=30\text{mA}$
	反向电流 Reverse current	I_R	-	-	10	μA	$V_R=6\text{V}$
输出 Out put	断态峰值电流 Peak Blocking Current	I_{DRM1}	-	-	100	nA	$V_{\text{DRM}} = \text{Rated } V_{\text{DRM}}$ $I_F = 0 \text{ mA } 2^*$
	峰值导通电压 Peak On-state Voltage	V_{TM}	-	-	3	V	$I_{\text{TM}}=100 \text{ mA peak,}$ $I_F=\text{Rated } I_{\text{FT}}$
	断态电压临界 上升率 Critical Rate of Rise off-state Voltage	dv/dt	1000	-	-	V/ μs	$V_{\text{PEAK}} = \text{Rated } V_{\text{DRM}, I_F=0\text{mA}}$ (Fig. 10) 3*
	抑制电压(MT1-MT2电压,高于该电压器件将不触发) Inhibit Voltage (MT1-MT2 voltage above which device will not trigger)	V_{INH}	-	-	20	V	$I_F= \text{Rated } I_{\text{FT}}$
抑制状态下的漏电 Leakage in Inhibited State	I_{DRM2}	-	-	500	μA	$I_F= \text{Rated } I_{\text{FT}}$ $V_{\text{DRM}}=\text{Rated } V_{\text{DRM, off state}}$	

附注(Notes):

1* Ta=25°C时的规格值 Typical values at Ta = 25°C

2* 测试电压必须在dv/dt额定值范围内 Test voltage must be applied within dv/dt rating

3* 这是静态的dv/dt, 转换直流dv/dt只有负载驱动晶闸管的函数

This is static dv/dt,Commutating dv/dt is a function of the load-driving thyristor(s) only

- 传输特性 (Ta=25°C, 除非另有规定)

Transfer Characteristics (Ta=25°C unless specified otherwise)

参数 Parameter		符号 Symbol	最小值 Min.	规格值 Typ.	最大值 Max.	单位 Unit	条件 Condition
LED触发电流 LED Trigger Current	KL3041-P5	I_{FT}	-	-	15	mA	主端子电压=3V Main terminal Voltage=3V 4*
	KL3042-P5		-	-	10		
	KL3043-P5		-	-	5		
保持电流 Holding Current		I_H	-	280	-	uA	

附注(Notes):

4* 所有设备都保证在小于或等于最大IFT的IF值触发. 因此, 建议工作IF介于最大IFT(KL3041-P5的15mA、10mA适用于KL3042-P5、5mA适合KL3043-P5)和绝对最大值(60mA)

All devices are guaranteed to trigger at an IF value less than or equal to max IFT. Therefore, recommended operating IF lies between max IFT (15 mA for KL3041-P5, 10 mA for KL3042-P5, 5 mA for KL3043-P5) and absolute maximum IF (60 mA)

7. 可靠性试验 Reliability Test

序号 NO.	试验项目 Test Items	参考标准 Reference	试验条件 Test conditions	试验过程 Test process	试验数 Qty.(pcs)	允收水准 LTPD
1	温度循环 TC	JESD22-A104C	H:125±5°C 15min J 5min L:-55±5°C 15min	300cycle	45	0/45
2	高温操作寿命 HTOL	JESD22-A108C	HTOL@110±5°C I _f =15mA I _c =AC 20mA	168、500、 1000hrs	45	0/45
3	高温反向偏压 HTRB	JESD22-A108C	HTRB@100±5°C V _{ce} =640V	168、500、 1000hrs	45	0/45
4	温湿度反向偏 压寿命试验 H3TRB	JESD22-A101- B	H3TRB@ 85±5°C、 85±5%RH V _{ce} =100V	168、500、 1000hrs	45	0/45
5	压力锅 Autoclave	JESD22-A102- C	T _a =121±5°C, 100%RH, 2atm	96hrs	45	0/45
6	高温储存 HTS	JESD22-A103C	HTS@125±5°C	168、500、 1000hrs	45	0/45
7	低温储存 LTS	JESD22-A119	LTS@-55±5°C	168、500、 1000hrs	45	0/45
8	耐锡热试验 RSH	JESD22-B106C	RSH@260±5°C	10sec*3times	45	0/45
9	可焊性 SD	JESD22-B102D	Pb-free@ 245±5°C	3sec*1times	22	0/22
备注 Remarks	以上试验项目如与客户试验要求存在差异或者特殊客户特殊要求的,可根据实际情况按照客户的要求进行试 作,客户未要求依我司试验标准试作,不同产品使用不同电流进行测试 All the tests should be performed according to customers' actual requirements, while difference of test standard or special requirements exist. Otherwise, all the tests are performed according to the standard listed above. Different current is applied to the tests of different product models					

8. 特性曲线 Characteristic Curves

图1. 正向电流与正向电压的关系
Forward Current VS Forward Voltage



图2. 导通特性
On-State Characteristics



图3. 保持电流 vs 环境温度的关系
Holding Current vs Ambient Temperature

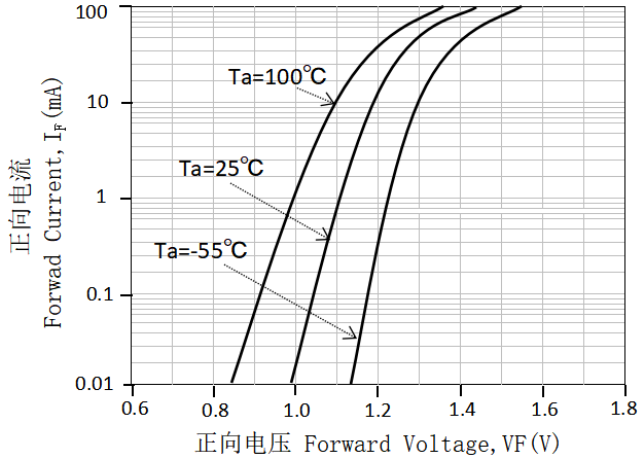

图4. 触发所需的LED电流 vs LED脉冲宽度的关系
LED Current Required to Trigger vs LED Pulse Width

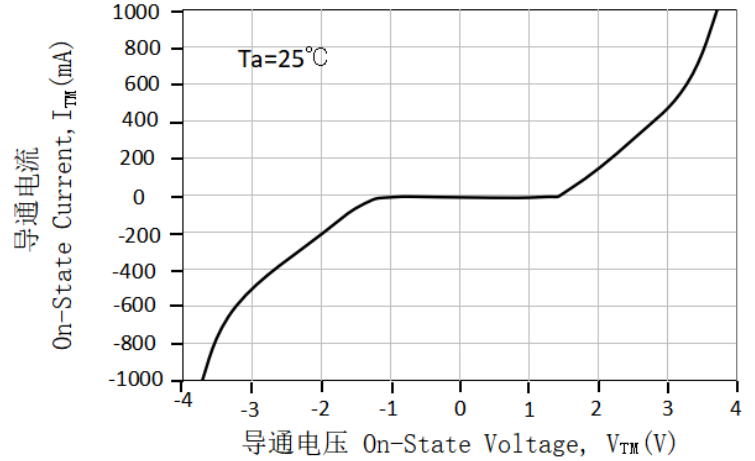

图5. 漏电流 vs 环境温度的关系
Leakage Current VS Ambient Temperature

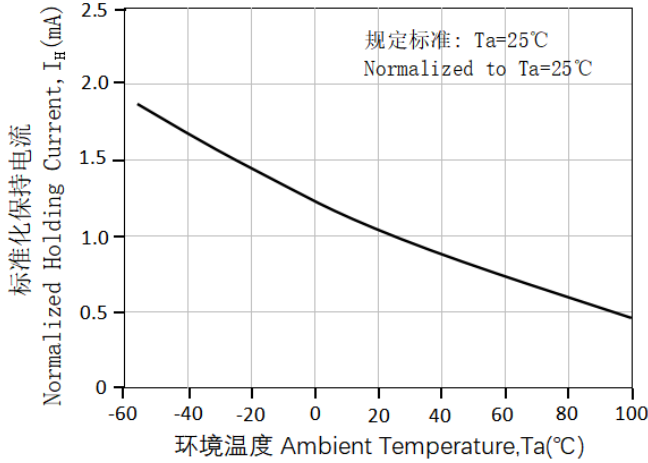

图6. LED触发电流 vs 环境温度的关系
LDE Trigger Current vs Ambient Temperature



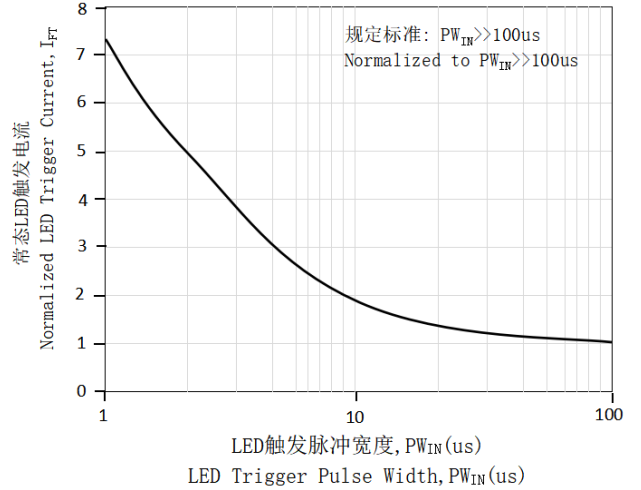

图10. 静态dv/dt测试电流和波形
Static dv/dt Test Circuit & Waveform

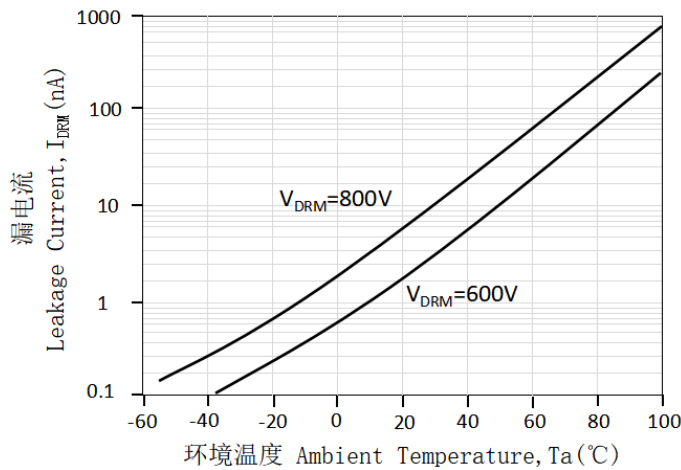
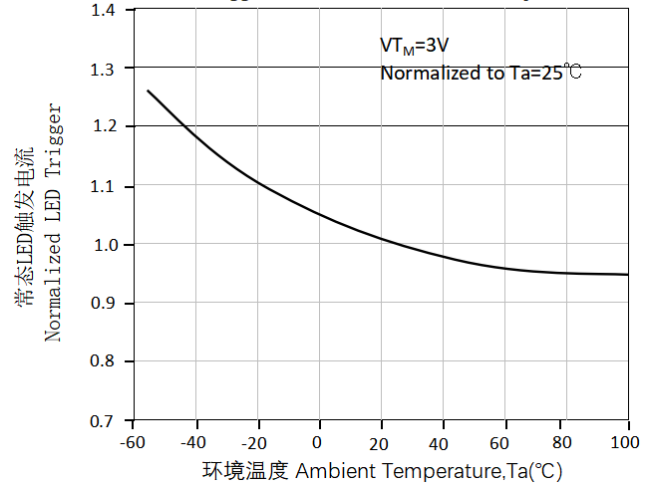

测量方法 Measurement Method

高压脉冲设置为所需的 V_{PEAK} 值, 并通过上述RC电路应用于D.U.T输出值, 不应用LED电流, 使用X100范围探头监视波形 V_T , 通过改变 R_{TEST} , dv/dt (斜率)增加, 直到DU被观察到触发(波形崩溃)。 dv/dt 随后下降, 直到D.U.T.停止触发, 此时记录 τ_{RC} , 计算 $dv/dt=0.632 \cdot V_{PEAK} / \tau_{RC}$

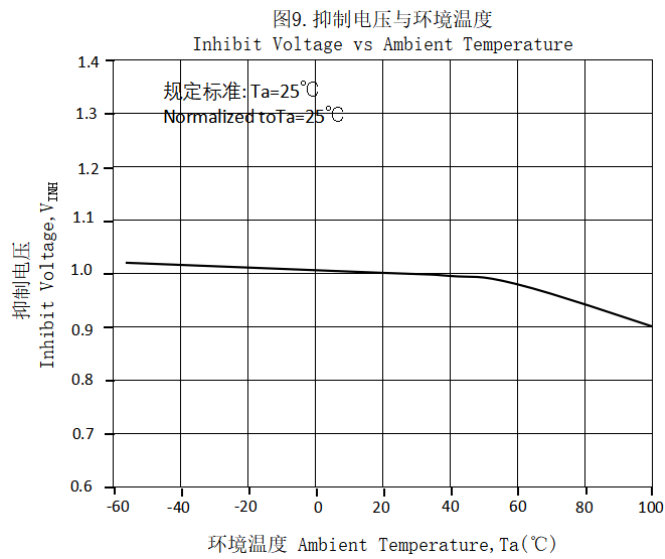
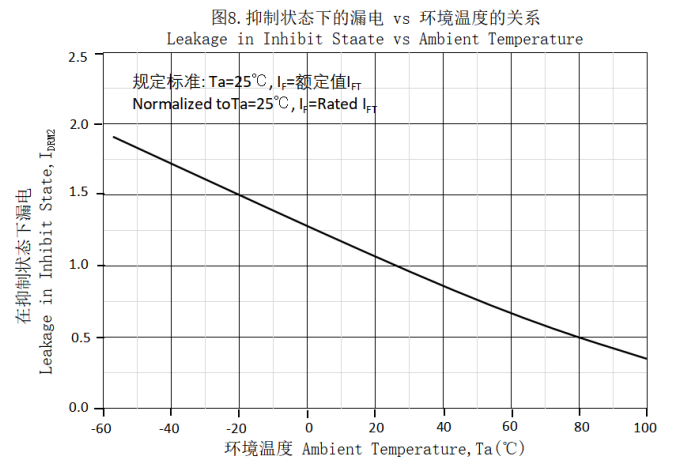
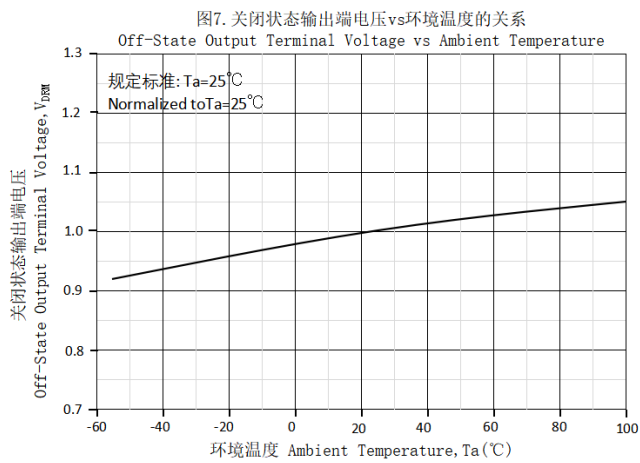
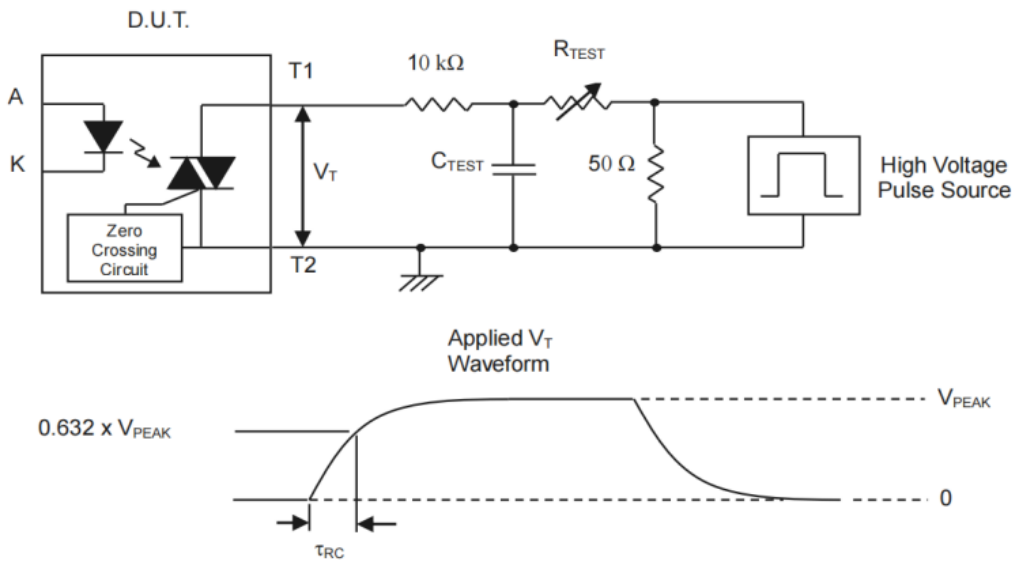
The high voltage pulse is set to the required V_{PEAK} value and applied to the D.U.T. output side through the RC circuit above. LED current is not applied. The waveform V_T is monitored using a x100 scope probe. By varying R_{TEST} , the dv/dt (slope) is increased, until the D.U.T. is observed to trigger (waveform collapses). The dv/dt is then decreased until the D.U.T. stops triggering. At this point, τ_{RC} is recorded and the dv/dt calculated. $dv/dt=0.632 \cdot V_{PEAK} / \tau_{RC}$

例如, KL304X-P5系列的 $V_{PEAK}=400V$, dv/dt 值的计算公式如下:

For example, $V_{PEAK} = 400V$ for KL304X-P5 series. The dv/dt value is calculated as follows:

$$dv/dt = 0.632 \cdot 400 / \tau_{RC}$$

9. 订单信息 Order Information

• 材料编号 Part Number

KL304XY(Z)(P5)-V

(料号PN:KL304XY-Z-P5-V)

附注(Notes):

X = 零件编号(1、2 或 3)

Part No. (1, 2 or 3)

Y = 引脚形式选项(S、S1、M 或 无)

Lead form option (S, S1, M or none)

Z = 料带和卷轴选项(TA、TB 或 无)

Tape and reel option (TA, TB or none)

P5 = 5引脚类型

5 pins type

V = 表示VDE标识(客户指定镭射字符才加"V")

VDE (Only add "V" to laser characters specified by the customer)

选项 Option	描述 Description	包装数量 Packing quantity
无 None	标准DIP-5 Standard DIP-5	每管65pcs 65 units per tube
M	宽引脚弯曲(0.4英寸间距) Wide lead bend (0.4 inch spacing)	每管65pcs 65 units per tube
S (TA)	表面贴装引线形式+TA载带和卷轴选项 Surface mount lead form + TA tape & reel option	每卷1000pcs 1000 units per tube
S (TB)	表面贴装引线形式+TB载带和卷轴选项 Surface mount lead form + TB tape & reel option	每卷1000pcs 1000 units per tube
S1 (TA)	表面贴装引线形式(低剖面)+TA载带和卷轴选项 Surface mount lead form (low profile) + TA tape & reel option	每卷1000pcs 1000 units per reel
S1 (TB)	表面贴装引线形式(低剖面)+TB载带和卷轴选项 Surface mount lead form (low profile) + TB tape & reel option	每卷1000pcs 1000 units per reel

10. 封装尺寸(单位:毫米) Package Drawing(Unit:mm)

- 标准DIP型号 Standard DIP Type

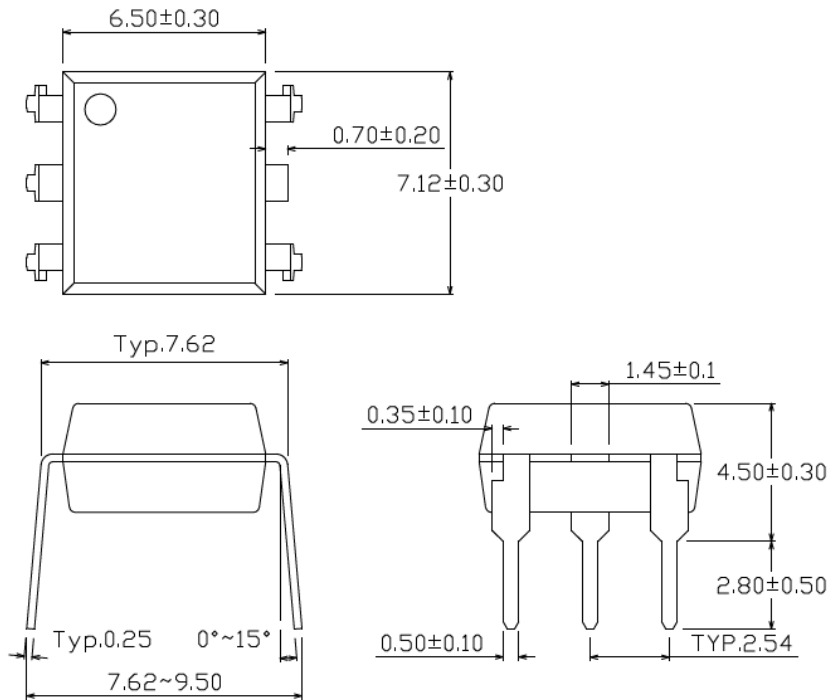

- 选择M型号 Option M Type

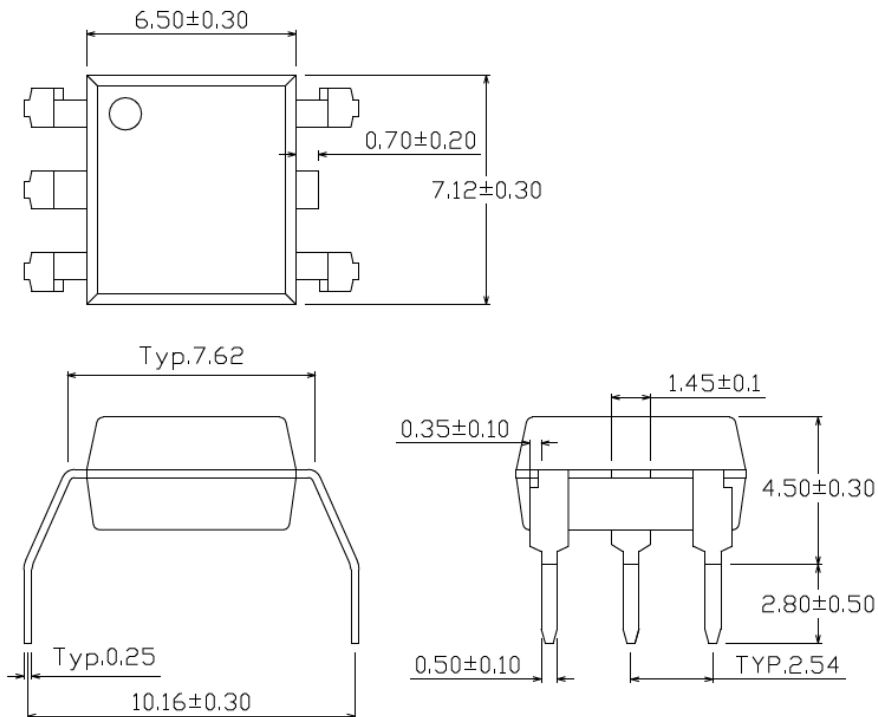

• 选择S型号 Option S Type

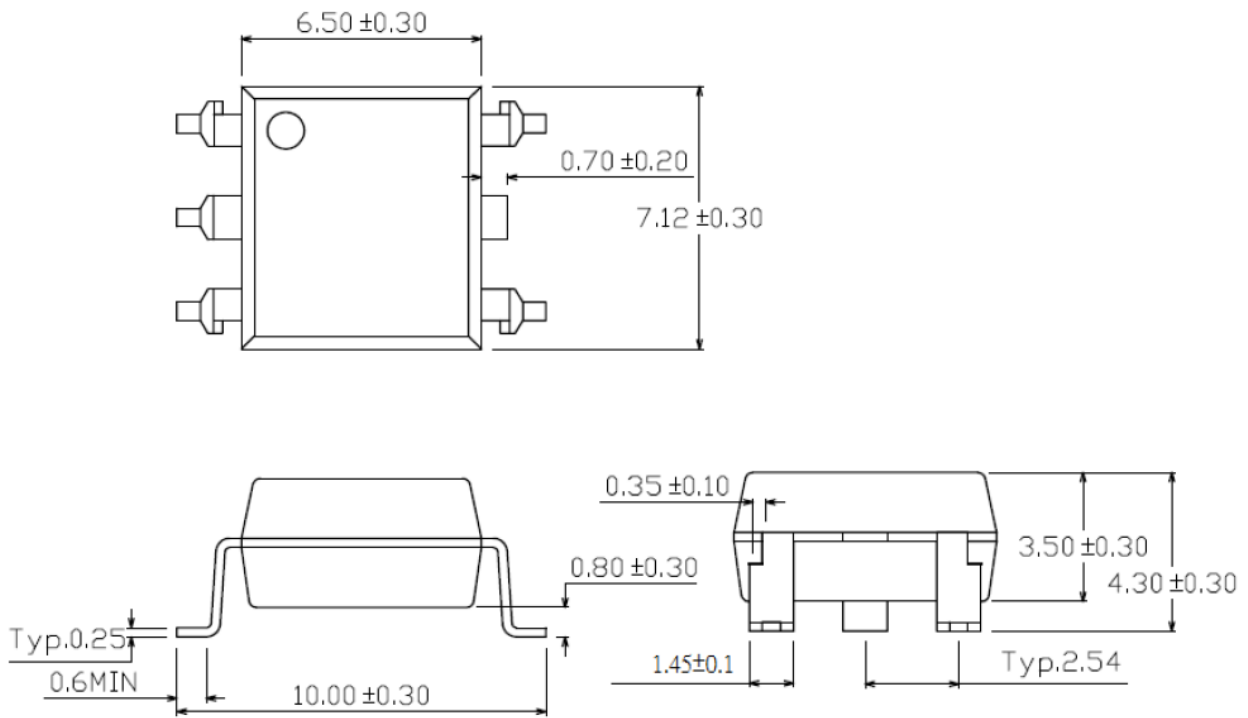

• 选择S1型号 Option S1 Type

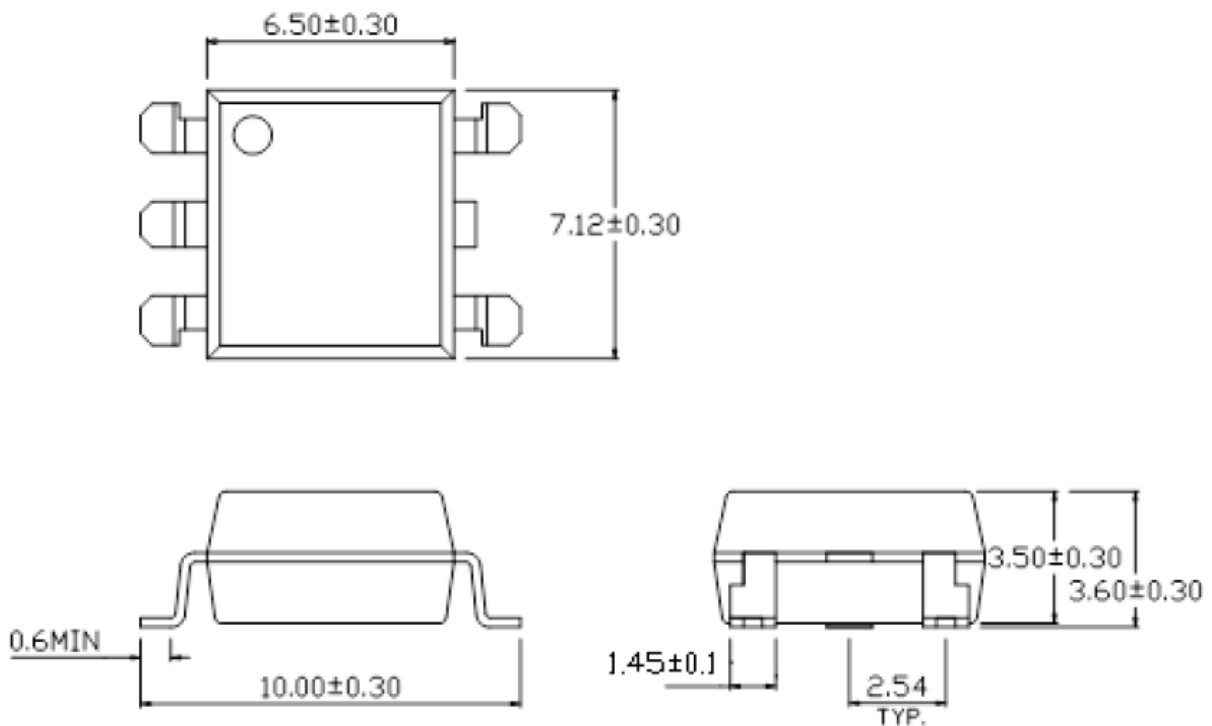

- 表面贴片类型PIN脚焊盘布局 Surface patch type PIN foot pad layout

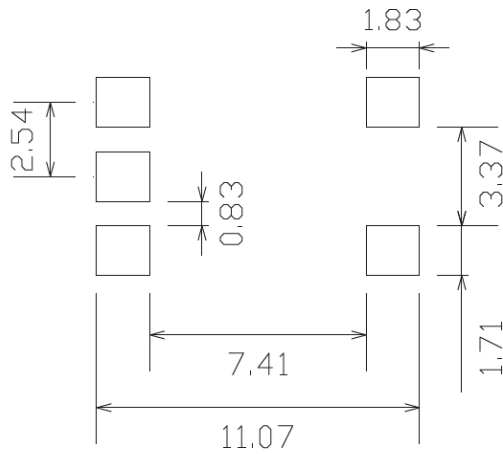

附注(Notes):

- 推荐焊盘尺寸仅供参考Suggested pad dimension is just for reference only
- 请根据个人需要修改焊盘尺寸Please modify the pad dimension based on individual need

11. 设备标记 Device marking

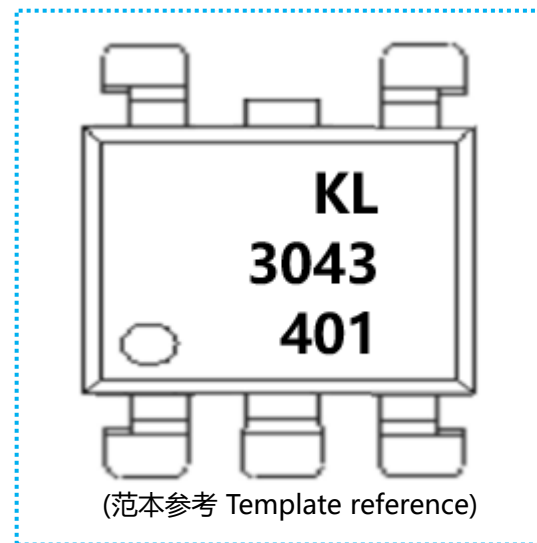
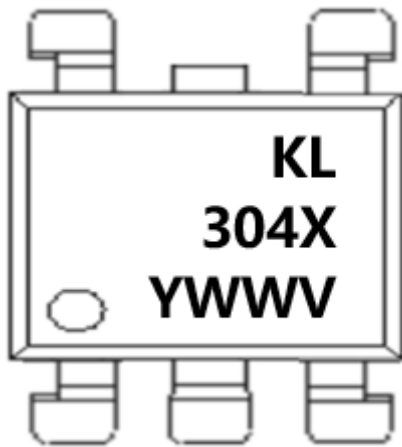

附注(Notes):

- KL = 表示晶台光电有限公司 Denotes KingLight
- 304X = 表示材料部件号 Denotes Device Part Number
X表示零件编号(1、2 或 3) Part No. (1, 2 or 3)
- Y = 表示1位年份代码 Denotes 1 digit Year code
- WW = 表示2位周别代码 Denotes 2 digit Week code
- V = 表示VDE标识(客户指定镭射字符才加"V")
VDE (Only add "V" to laser characters specified by the customer)

12. 料带和卷轴包装规格 Tape & Reel Packing Specifications

• 选择TA Option TA

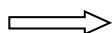
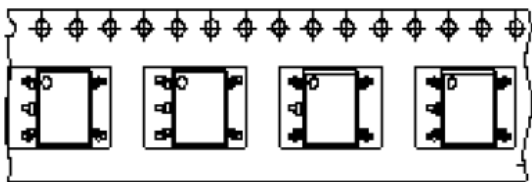

卷轴进给方向 Direction of feed from reel

• 选择TB Option TB

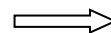
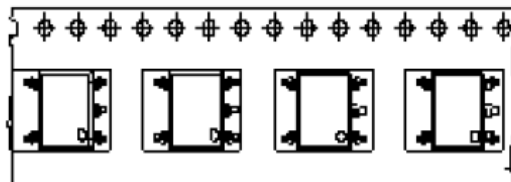

卷轴进给方向 Direction of feed from reel

料带尺寸 Material belt size

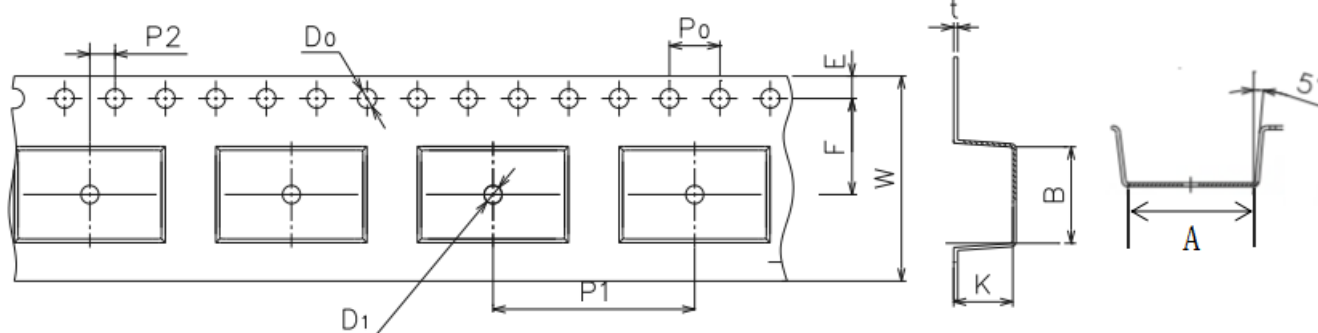

尺寸编号 Dimension No.	A	B	D0	D1	E	F
尺寸(mm) Dimension(mm)	10.8±0.1	7.55±0.1	1.5±0.1	1.5±0.1	1.75±0.1	7.5±0.1
尺寸编号 Dimension No.	P0	P1	P2	t	W	K
尺寸(mm) Dimension(mm)	4.0±0.15	16.0±0.1	2.0±0.1	0.35±0.03	16.0±0.2	4.5±0.1

13. 焊接温度曲线 Temperature Profile Of Soldering

• 回流焊焊接条件 Reflow soldering Soldering Condition

建议在下面所示的温度和时间分布条件下, 进行一次回流焊作业, 不得超过三次

One time soldering reflow is recommended within the condition of temperature and time profile shown below. Do not solder more than three times.

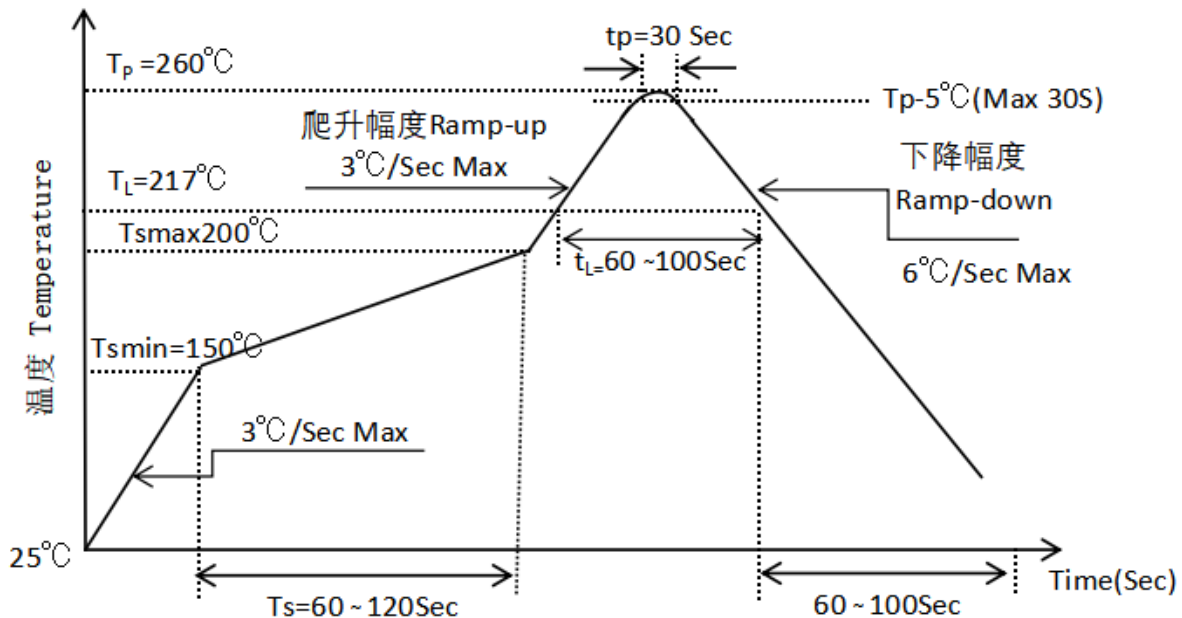

项目 Item	符号 Symbol	最小值 Min.	最大值 Max.	单位 Unit
预热温度 Preheat Temperature	T_s	150	200	°C
预热时间 Preheat Time	t_s	60	120	s
升温速率 Ramp-Up Rate (T_L to T_P)	-	-	3	°C/s
液相线温度 Liquidus Temperature	T_L	217		°C
高于液相线温度(T_L) 的时间 Time above Liquidus Temperature T_L	t_L	60	100	s
峰值温度 Peak Temperature	T_P	-	260	°C
T_c 在(T_P-5)和 T_P 之间的时间 Time During Which T_c Is Between (T_P-5) and T_P	t_p	-	30	s
降温速率 Ramp-down Rate(T_P to T_L)	-	-	6	°C/s

• 波峰焊温度曲线 Wave Soldering

温度条件下, 建议一次焊接

One time soldering is recommended within the condition of temperature

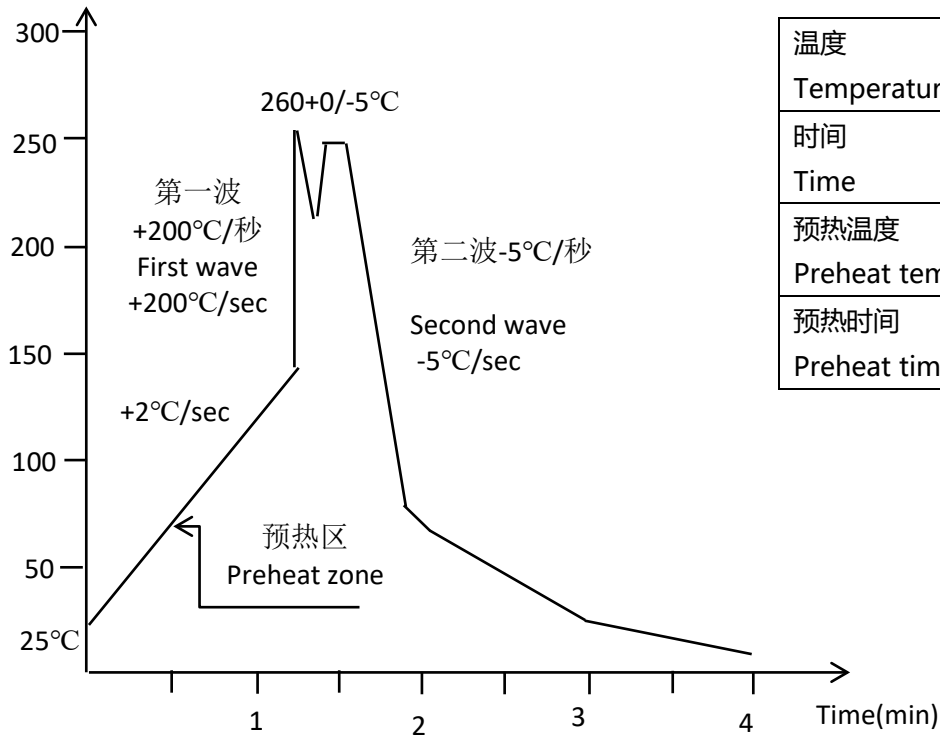

温度 Temperature	260°C+0/-5°C
时间 Time	10秒 10S
预热温度 Preheat temperature	25至140°C 25 to 140°C
预热时间 Preheat time	30至80秒 30 to 80 S